

GUIDELINES FOR RELIABLE LONG LINE 1-WIRE NETWORKS

Abstract: The 1-Wire® protocol was originally designed to facilitate communication with nearby devices on a short connection. 1-Wire was also a way to add auxiliary memory on a single microprocessor port pin. Methods were later developed to extend the 1-Wire protocol to network applications well beyond the size of a circuit board. This document discusses various aspects of 1-Wire networks and provides design guidelines for their reliable operation.

Introduction

Every 1-Wire network is different, often both in topology (layout) and hardware.

A proper match among network components (i.e., master, network cabling, and 1-Wire slave devices, "slaves") is the precondition for reliable 1-Wire operation. When bus masters are improperly designed or implemented, or when masters intended for short-line use are pressed into service with greatly extended communication lines, then satisfactory performance cannot always be expected.

This application note presents the results of a project to characterize the operation of 1-Wire networks of various forms, sizes, and populations. It also provides working parameters for reliable network operation. Some of the aspects discussed here are not critical in short-line applications, e.g. networks of less than 1 meter.

Network Description

The scope of this document is limited to 1-Wire networks that use Category 5e, twisted-pair copper wire and have 5V bus power supplied by the master. (Most 1-Wire slaves will operate at lower bus voltages, but large networks often have too much loss to perform well under low-voltage conditions.)



It is recommended to use data cable (Cat5e, Cat6 or Cat7). Use the same twisted pair for both GND and DQ (data). DQ and GND should be connected using a single twisted pair so the data signal is twisted together with GND.

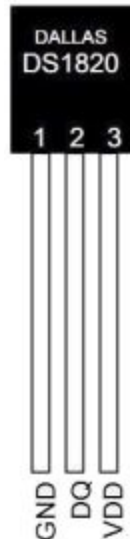

For longer distances or when running alongside mains cables use STP (shielded twisted pair) cable.

This document does not address the requirements for programming EPROM-type slave devices. It is generally not recommended that EPROM programming be performed at any appreciable distance from the master-end interface. This article also does not discuss overdrive speed operation of 1-Wire devices. The overdrive speed is intended for use only on very short connections and is never suitable for use in 1-Wired networks.

There are countless combinations of wire types and topologies that can be used with 1-Wire devices. This application note attempts only to describe the most general and typical applications associated with the 1-Wire network. Operating a 1-Wire network beyond the limits or disregarding advice given in this document may result in unreliable network performance.

1-Wire Network Terminology

Two simple terms describe measurements that are critical to 1-Wire network performance: radius and weight.

- The radius of a network is the wire distance from the master end to the most distant slave. It is measured in meters.
- The weight of a network is the total amount of connected wire in the network. It is also measured in meters.

For example, a star network configuration with three branches of 10m, 20m, and 30m would have a radius of 30m (i.e., the distance from 1-Wire master to the furthest slave) and a weight of 60m (i.e., the total length of wire in the network, 10m + 20m + 30m).

In general, the weight of the network limits the rise time on the cable, while the radius establishes the timing of the slowest signal reflections.

Slave Device Weight

The weight that can be supported in a network is limited, and depends on the driver (1-Wire master interface). In simple terms, the weight can consist of many slaves on very little cable, or very few slaves on a lot of cable.

Slave devices (iButtons® and other 1-Wire devices) add equivalent weight to a network. Each device adds weight similar to that of a small length of wire, so devices can be rated in terms of their equivalent wire weight. Consequently, when a network is designed, the weight of the devices must be considered. A slave in iButton form usually contributes more weight than a slave packaged as a soldered-in component. iButtons add a weight of about 1m, and non-iButton slaves add a weight of about 0.5m. Consider the implications of this for an example network. Connecting 100 iButton devices increases the total network weight by 100m, which in turn, requires the total amount of wire to be reduced by 100m to keep the network functioning.

Circuit-board traces, connectors, and ESD protection devices also add weight to a network.

Although weight is influenced by many factors, capacitance is clearly the largest single contributor. For example, the weight contribution of Category 5e unshielded twisted pair (UTP) can be related to their capacitance by a factor of about 52pF/m at 1-Wire speeds. As a general rule, the weight contribution of ESD circuits and

PC-board traces can be related to their capacitance by a factor of about 24pF/m. A circuit-board trace or device that exhibits 24pF across the 1-Wire bus will add a weight of about 0.5m.

1-Wire Network Topologies

Although 1-Wire networks are often quite "free form" in structure, they usually fit into a few generalized categories, based on the distribution of the 1-Wire slaves and the organization of the interconnecting wires.

1. Linear topology. The 1-Wire bus is a single pair, starting from the master and extending to the farthest slave device. Other slaves are attached to the 1-Wire bus with insignificant (< 3m) branches or "stubs."

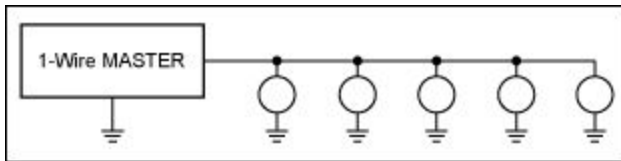

2. Stubbed topology. The 1-Wire bus is a single main line, starting at the master and extending to the farthest slave. Other slaves are attached to the main line through branches or stubs 3m or more in length.

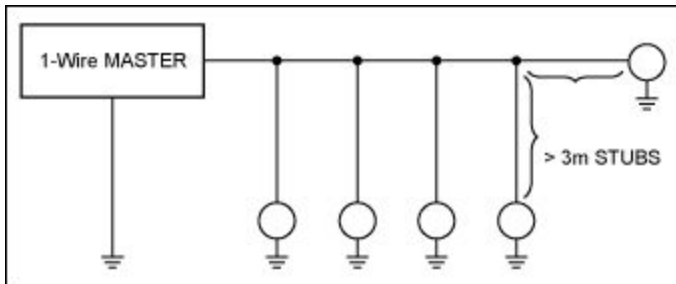

3. Star topology: The 1-Wire bus is split at or near the master end and extends in multiple branches of varying lengths. There are slave devices along, or at the ends of, the branches.

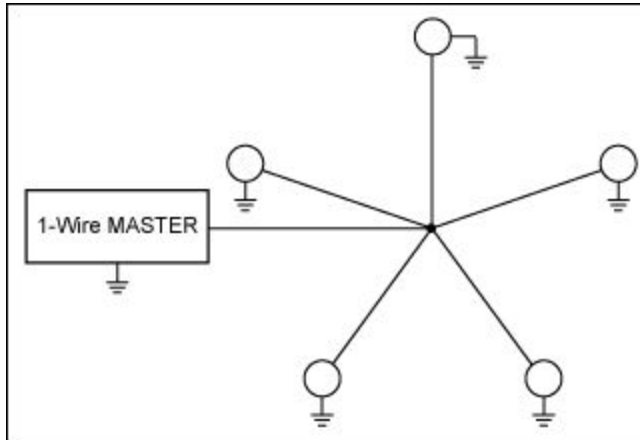

When different topologies are intermixed, it becomes much more difficult to determine the effective limitations for the network. As a rule, the designer should apply the most conservative of the criteria in these cases.

Precautions with Star Topologies

Testing has shown that unswitched star-type network topologies (i.e., those with several branches diverging at the master) are the most difficult to make reliable. The junction of various branches presents highly mismatched impedances; reflections from the end of one branch can travel distances equal to nearly the weight of the network (rather than the radius) and cause data errors. For this reason, the unswitched star topology is not recommended, and no guarantees can be made about its performance.

Switched Networks

To allow networks to grow in complexity without growing in weight and radius, the network is divided into sections that are electronically switched on one at a time. Using low-impedance, single-supply analog switches, the network can *physically* resemble one topology, but *electrically* resemble another. This means that a star configuration with a switch on each branch would actually resemble a linear topology. In this case, only one branch is active at any time.

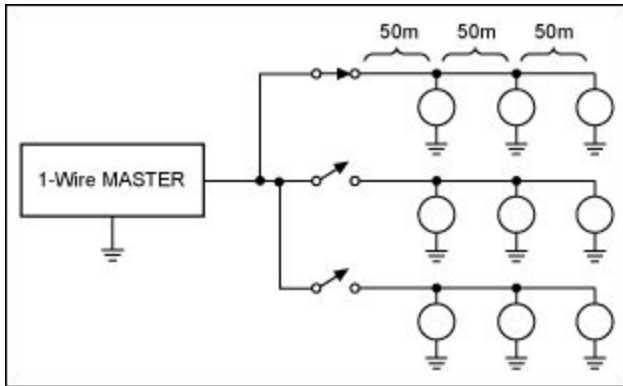

The example above appears like a star topology network with a radius of 150m and a weight of 450m. However, when each switched path is considered individually, the network is actually a linear topology and the weight is only 150m.

As a rule, our discussion of non switched networks can be applied to each segment of a switched network.

1-Wire Network Limitations

Several factors determine the maximum radius and weight of a network. Some of these factors can be controlled and some cannot.

The master-end interface greatly influences the allowable size of a 1-Wire network. The interface must provide sufficient drive current to overcome the weight of the cable and slaves. It must also generate the 1-Wire waveform with timings that are within specification and optimized for the charge and discharge times of the network. Finally, the interface must provide a suitable impedance match to the network, so that signals are not reflected back down the line to interfere with other network slaves.

When the network is small, very simple master-end interfaces are acceptable. Capacitance is low, reflected energies arrive too soon to pose a problem, and cable losses are minimal. A simple active (FET) pulldown and passive (resistor) pullup are sufficient. But, when lines lengthen and more devices are connected, complex forces come into play. Now the master-end interface must be able to handle them all.

The network radius is limited by several factors: the timing of waveform reflections, the time delay produced by the cable, the resistance of the cable, and the degradation of signal levels. The typical signal propagation speed in a phone cable is about 2/3 of the speed of light. In a 750m cable, for example, the roundtrip delay is 7.5 μ s. If the master pulls the line low for 7.5 μ s to start a read time slot, then the end of the master's low pulse (i.e., after a roundtrip) coincides with the instant at which a

near-end fast slave may stop pulling the line low. Consequently, the roundtrip delay of such a long cable makes it impossible for the master to communicate with that near-end slave.

Network weight is limited by the ability of the cable to be charged and discharged quickly enough to satisfy the 1-Wire protocol. A simple resistor pullup has a weight limitation of about 200m. Sophisticated 1-Wire master designs have overcome this limitation by using active pullups, that provide higher currents under logic control and have extended the maximum supportable weight to over 500m.